

YELLOWSHIP20

The Better Work Conference

Sept. 22-24 | 2020 INDY



POWERED BY *Lessonly*



WHAT IS YELLOWSHIP?



A place for learners, leaders, & llamas.

Yellowship 20 will bring together more than 500 of the world's greatest trainers, enablers, and thought leaders for three days of learning and fellowship, powered by Lessonly. High-performing people will find inspiration, camaraderie, and advice for moving their teams onward and upward.

Why attend Yellowship?

Yellowship is all about learning from one another and from the world's most intriguing innovators. If your team is growing quickly, pursuing innovation, or looking to Do Better Work, Yellowship 20 is for you.



Clarity

When teams have clarity, ambiguity disappears. Everyone knows what matters, why it matters, and what they should do about it.



Camaraderie

Teammates that learn together, win together. Learn strategies and tips to move your team towards a place of mutual trust and respect.



Progress

Progress is the byproduct of healthy team camaraderie and clarity. Want to reach new heights? Yellowship 20 will help you get there.

WHAT

VENUE

REVIEW

SPONSORSHIP PACKAGES

ADD-ONS

VENUE



Historic Union Station

123 W. Louisiana St. Indianapolis, IN 46225

Historic place. New ideas.

Union Station, Indianapolis' landmark train station, is the home of Yellowship 20 and your hub for exploring the Circle City—a rising tech hub with Midwestern vibes. As the fifth-best city in the U.S. for tech industry growth (Forbes & CBRE), and one of the 15 hottest tech cities in the U. S. (Time), Indy is home to a new generation of startups—including Lessonly.

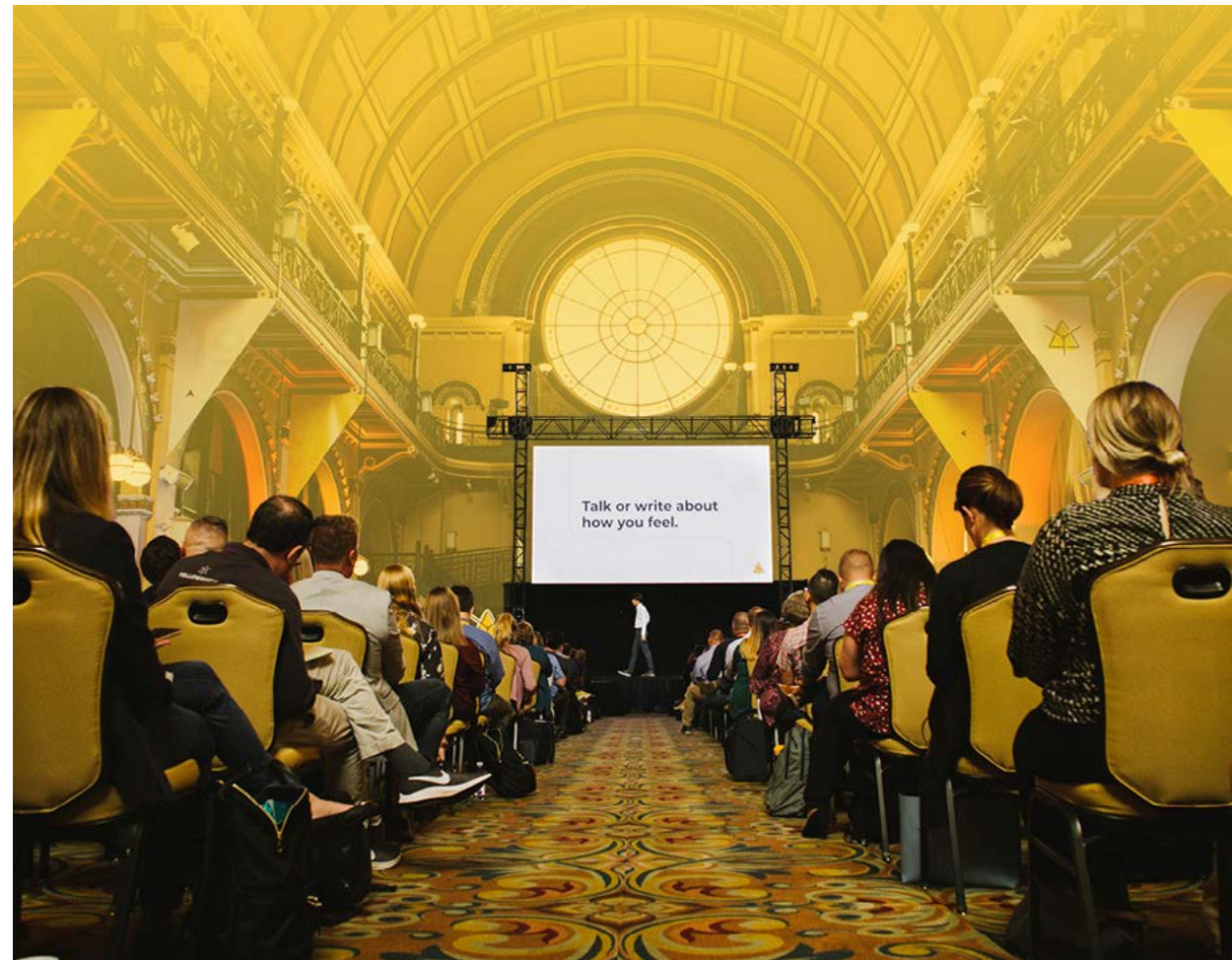

WHAT

VENUE

REVIEW

SPONSORSHIP PACKAGES

ADD-ONS

YELLOWSHIP19

IN REVIEW

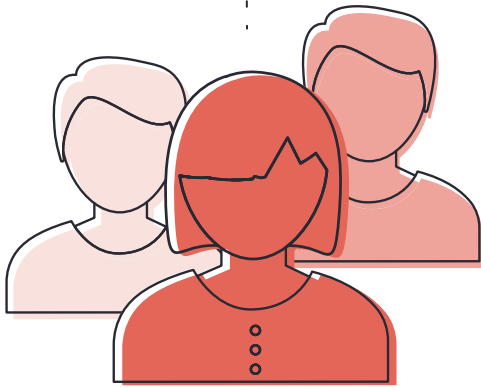

500 Attendees

2019 Sponsors

zendesk

CHIRUS

Hippo Video

tymeshift

Gregory & Appel
INSURANCE

MaestroQA

SUPPORT
NINJA

ADVISA

#GirlsClub

Companies that joined us in 2019

INDUSTRIOUS

Jostens

THRIVE
- MARKET -

emarsys

zendesk

Dia & Co

WHAT

VENUE

REVIEW

SPONSORSHIP PACKAGES

ADD-ONS

Attendee Titles

- Director, Customer Success
- Director, Sales Enablement
- Director, Call Center Operations
- Director, Training & Development
- Learning & Development Manager
- Sales Enablement Manager
- Customer Service Trainer

Job Level

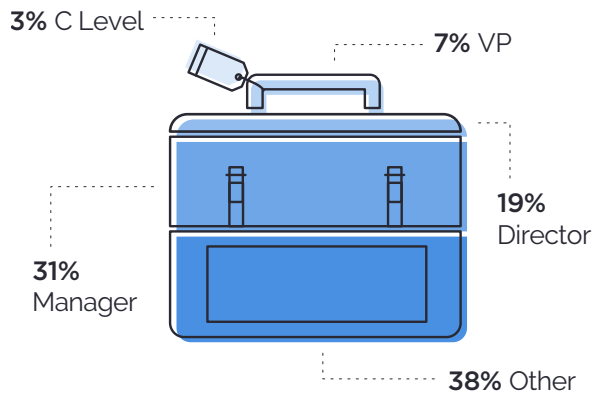

Job Function

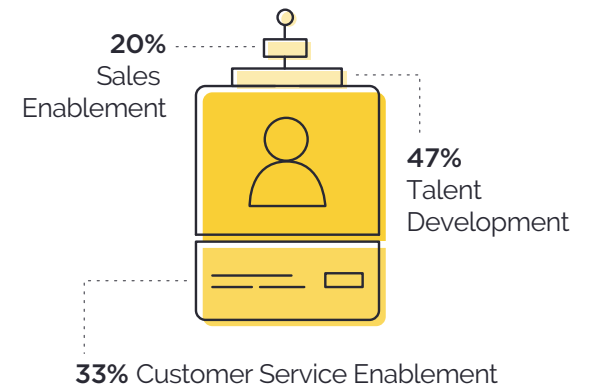

SPONSORSHIP PACKAGES



Platinum Sponsor

\$30,000 | 1 available

- 6-foot table in the expo hall
power, internet, & lead scanning license included
- Opportunity to speak for 2 minutes on the keynote stage OR a dedicated breakout session
- 6 full conference passes for staff
- Facilitated one-on-one introductions to 5 target prospects
- Branding on Yellowship website and printed agendas
- Premium branding on signage throughout the event
- List of attendees
including name, title, company, address, & phone number

Gold Sponsor

\$20,000 | 4 available

- 6 ft table in the expo hall
power, internet, & lead scanning license included
- Inclusion on a panel in a breakout session
- 3 full conference passes for staff
- Facilitated one-on-one introductions to 2 target prospects
- Branding on Yellowship website and printed agendas
- Premium branding on signage throughout the event
- List of attendees
including name, title, company, address, & phone number

Silver Sponsor

\$15,000 | 5 available

- Cocktail table in the expo hall
power, internet, & lead scanning license included
- 2 full conference passes for staff
- Branding on the Yellowship website and printed agendas
- Branding on signage throughout the event

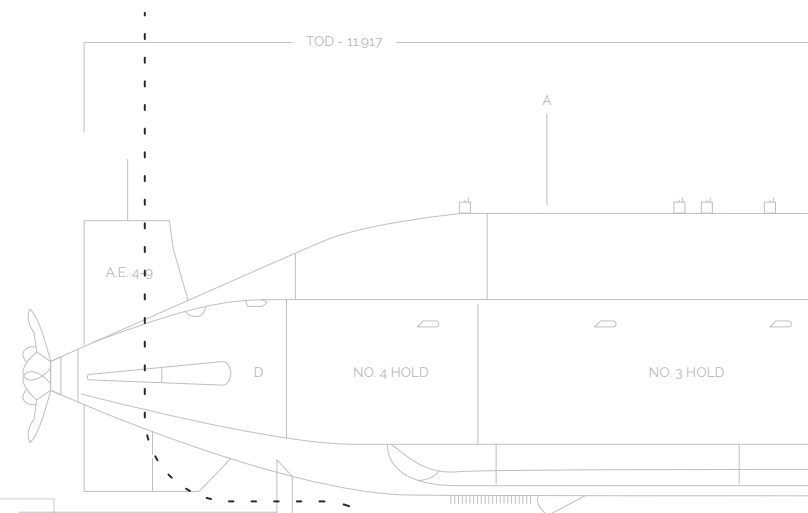

WHAT

VENUE

REVIEW

SPONSORSHIP PACKAGES

ADD-ONS

SPONSORSHIP ADD-ONS



Opening Reception Sponsor

\$10,000 | 1 available

- Branding on signage, napkins, and tables at the reception
- Signature cocktail named by you
- Branding on signage throughout the event
- Branding on Yellowship website and printed agendas

Technology Sponsor

\$4,000 | 1 available

- Provide wifi for guests
(login will be your company name)
- Branding on all wifi signage
- Branding on Yellowship website and printed agendas

Breakfast Sponsor

\$3,000 | 2 available

- Branding on signage, napkins, and tables at breakfast
- Branding on signage throughout the event
- Branding on Yellowship website and printed agendas

Lunch Sponsor

\$3,000 | 2 available

- Branding on signage, napkins, and tables at lunch
- Branding on signage throughout the event
- Branding on Yellowship website and printed agendas

Swag Sponsor

\$3,000 | 1 available

- Branding on a piece of swag given to attendees by Lessonly
- Branding on signage throughout the event
- Branding on Yellowship website and printed agendas

Snack Sponsor

\$2,000 | 1 available

- Branding on signage, napkins, and tables at Wednesday's snack
- Branding on signage throughout the event
- Branding on Yellowship website and printed agendas

WHAT

VENUE

REVIEW

SPONSORSHIP PACKAGES

ADD-ONS



Ready to

CLIMB ABOARD?

EMAIL US

yellowship@lessonly.com

LEARN MORE

lessonly.com/yellowship

